

Ceiling Sound Reflectors

Auralex's Ceiling Sound Reflectors enable sound reflection and tuning in performance halls, music practice rooms, and auditoriums. Without some sound reflection, these halls and rooms would sound dull and flat. By adjusting the sound-reflective surfaces to optimize their acoustical performance, rooms can be "tuned".

Our Ceiling Sound Reflectors are hard enough to reflect sound, while allowing for installations at any angle and height. Shape your ceiling to create ideal sound reflection.

Installed below the actual ceiling, our reflectors direct sound to the audience before being lost or reflected off the higher ceiling. We offer three shapes of reflectors - radial, flat and serpentine.

Core

Radial: 1/2" 5 ply plywood
 Flat: 1/2" 5 ply plywood
 Serpentine: 1/2" 5 ply plywood

Sizes

Custom sizes up to 4'x10'

Mounting

By Others

Finish

Laytex Paint, Fabric
 Wood, Laminate

Flammability

All components have a Class "A" rating per ASTM E84

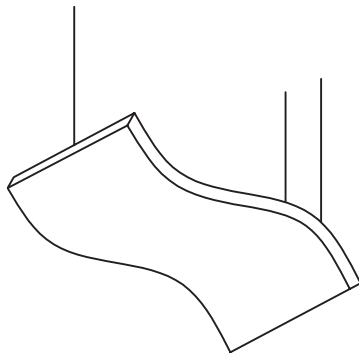
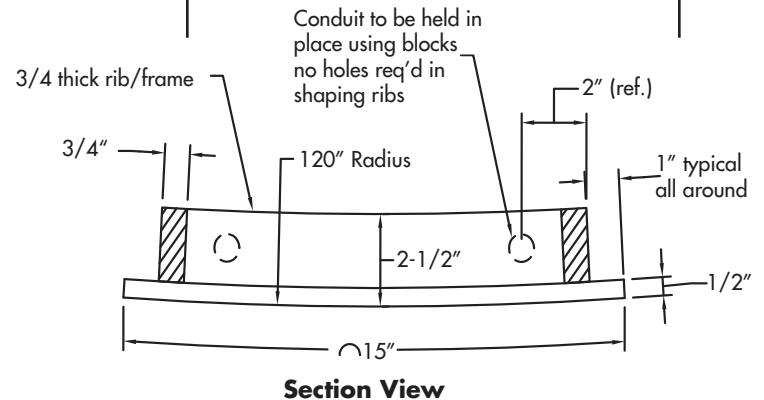

Serpentine Reflector

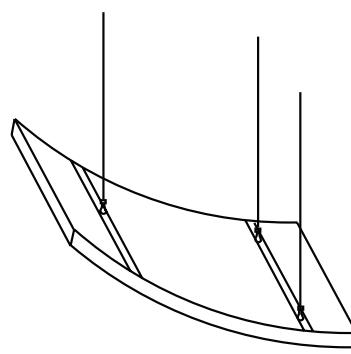

Radial Reflector

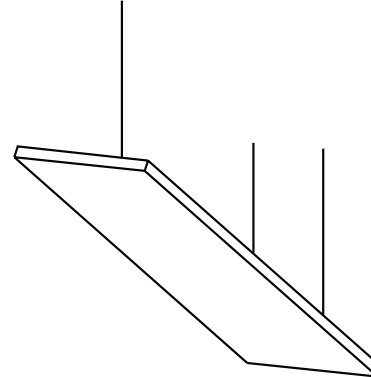

Flat Reflector